

Introducing...
Introducing...

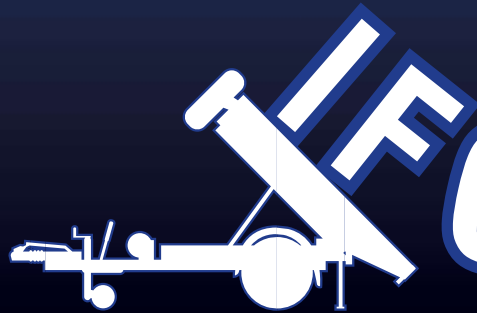

OR WILLIAMS TRAILERS



For Williams

For Williams

For Williams
Trailers

ZIPPER

ZIPPER

ZIPPER

ZIPPER

ZIPPER

ZIPPER

ZIPPER

ZIPPER

For Williams Trailers

For Williams Trailers

Single Axle Tipper Model TT2012

- Steel welded and galvanised chassis
- A-frame drawbar design
- Steel welded and galvanised tipping platform
- Steel sides and bed construction
- Heavy duty 3 stage hydraulic ram
- Heavy duty manual pump
- Cast heavy-duty coupling and head
- Solid beam axle rated to 1500kg
- 200mm brakes
- Rugged 185/70R13 tyres
- Renowned IWT leaf suspension
- Novel skip back and tailboard
- Body latch for security and safety





Along with this list of outstanding features, the trailer comes with rope hooks, prop-stands, tailboard and spare wheel, all fitted as standard. Optional accessories available are:

- Mesh sides
- Ladder rack
- Tarpaulin cover
- Light guards

The trailer has been designed to provide maximum carrying capacity on a single axle. The TT2012 weighs in at just under 400kg. Plated with a GVW of 1,500Kg, this new model bridges the gap between the unbraked range and our higher payload, existing Tipping trailer range.

Users will welcome the 1100kg payload easily accommodating a 1 tonne builder bag or generous load of logs, gravel, rubble, garden debris etc.

Users with lighter towing vehicles will now have the option of purchasing a professional grade trailer benefitting from it's much sought after features, inherent in all IWT products.









Prop Stands

Fitted as standard to provide additional stability when required. These are common to other products in the IWT range, such as the P6e, GD & BV4.



Trailer Features

Manual Pump

The manually operated hydraulic pump comes with a new 6L rust proof tank for a long and reliable life.



Trailer Features



Rope Hooks

The trailer is fitted as standard with rope hooks giving extra security when used with rope or tarpaulin.

Trailer
Features

Skip Back & Tail Board

The trailer has been designed with a skip back making tipping easy.

The tailboard provides a closed back to ensure rubble and loose materials are retained during transit.



Trailer Features



Wheels & Tyres

The trailer is fitted with the rugged 185/70R13 tyres.

Spare wheel comes as standard.





Body Latch

The trailer incorporates a body latch locking the tipping platform into place. This is beneficial when travelling over rough and uneven ground.

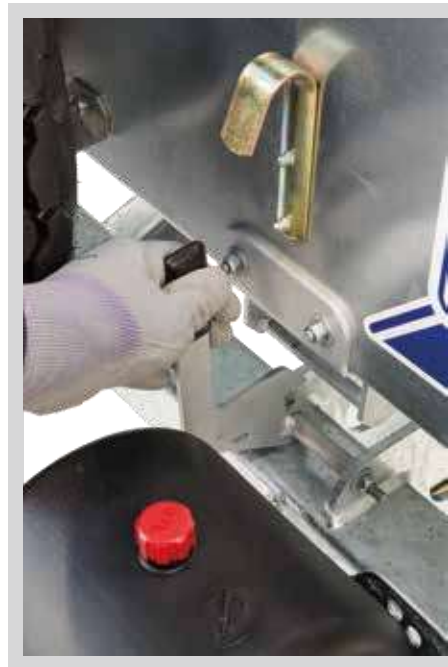

Trailer Features



For Williams
Trailers

FOR WILLIAMS TRAILERS

For Williams Trailers Ltd.



Light Guards

Common with our other tipping trailers the road legal rear light guards offers protection when tipping, preventing the lights from being damaged.

Mesh Sides

Accessories





For supporting long items the optional ladder rack is available.

As with the mesh side kits the ladder rack is common with the P6e.

The tarpaulin cover is available to enhance the trailer and provides convenient cargo restraint for loose items.





Ifor Williams Trailers

IFOR WILLIAMS TRAILERS

Ifor Williams Trailers Ltd.



ZIPPER

N6 KGF

Zipper Trailers

Specification

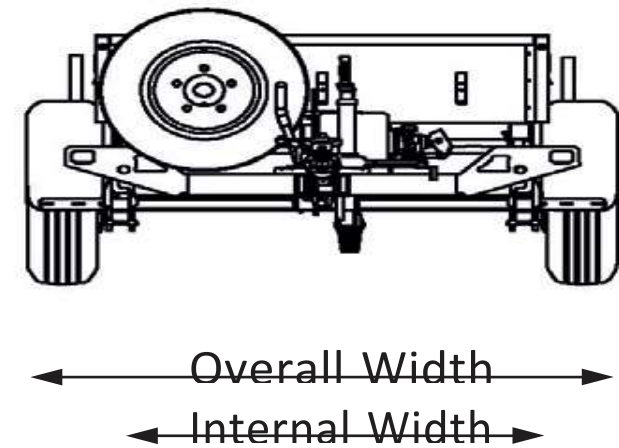
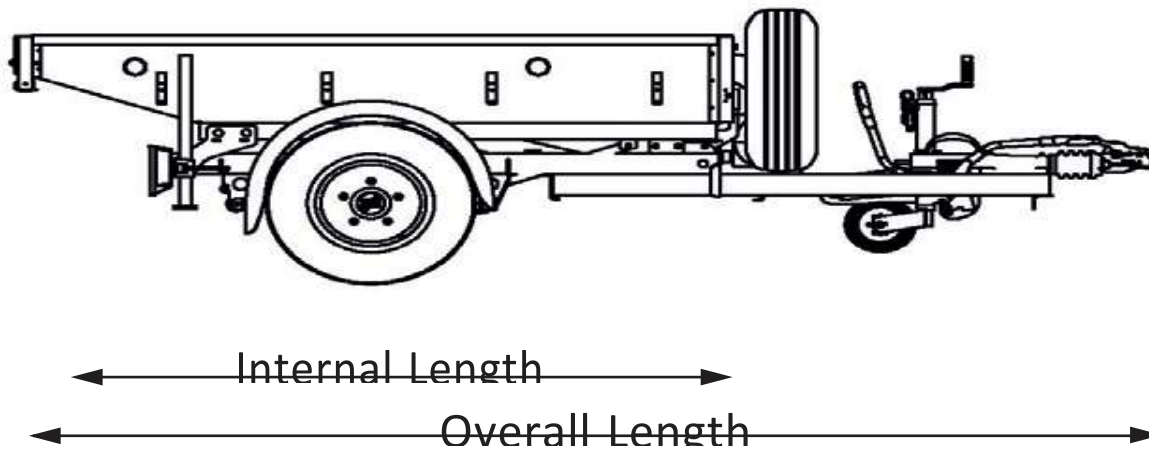

TT2012	Tyres	Gross Weight	Unladen Weight	Internal Length	Internal Width	Overall Length	Overall Width	Tipping Angle
TG382012151	185/70R13	1500kg	398kg	1975mm	1220mm	3270mm	1710mm	57°



IFOR WILLIAMS TRAILERS

TIPPER

IFOR WILLIAMS TRAILERS

TIPPER

IFOR WILLIAMS TRAILERS

TIPPER

SCORPION



HBM
HBE

Williams
Meters

Spare Parts









Ifor Williams

Trailers[®]

Ifor Williams Trailers® 60

CELEBRATING 60 YEARS OF ENGINEERING EXCELLENCE

